



Oil Filter Mount 65/20x1.5
Part #100012

WARNING! Please read the whole guide before installing this part.

Legals:

TAARKS oil filter block has been designed and is intended for off-road use only. The installation of this part on a vehicle intended for use on public roads may violate laws and regulations in your country/state. Additionally, this part is sold with a LIMITED warranty that only covers defects in manufacturing. This warranty does not cover any damage incurred by using this part. The installation of this part may also void any vehicle warranties. Refer to a performance specialist for proper installation.

After opening the packaging please check to see if any parts are missing or damaged. If something is missing or damaged please contact us immediately. Do not install the product.

Do not modify this part in any way. Modifying the part may result in failure of the part and voids all possible warranties.

Installation Guide

Install the short end of the stainless steel adapter into the aluminium housing. The end with the longer thread faces out. Hold the aluminium housing in a vice with aluminium jaws when tightening the adapter.



Use the supplier M5 counter sunk screws to mount the stainless steel bracket onto the aluminium housing. The bracket can be installed pointing up or down. (Pointing up makes it easier when installing onto the vehicle)



The aluminium housing has a M12x1.5 threaded port to accept a temperature sensor. If you are not using a temperature sensor install the supplied plug as shown below.



Install the o-rings onto the AN10 ORB fittings as shown below.



Apply a small amount of oil to the o-rings and install the fittings into the housing.



The aluminium housing has 2x 1/8" NPT ports for temperature and pressure sensors. If you plan on using a pressure sensor the preferred port is lower port in the picture below, this will measure oil pressure after the filter.

The kit is supplied with 2x 1/8" NPT plugs if no sensors are to be installed. Apply some thread tape to the plugs and install them into the aluminium housing as shown below.



The last step is to find a suitable place in the engine bay to mount the oil filter housing and connect your oil lines. –See next page for plumbing layouts.



Please note that oil will only flow in one direction through an oil filter due to the internal check valve. Ensure the lines are plumbed correctly during installation. Oil should flow from the engine or oil cooler to the outside of the oil filter and return to the motor from the center of the oil filter.

NOTE: This oil filter mount suits oil filters that are 65mm diameter and have a M20x1.5mm thread. These are commonly found on the Nissan S14/S15 motors. Ryco Z445

Typical plumbing layouts:

With oil cooler...

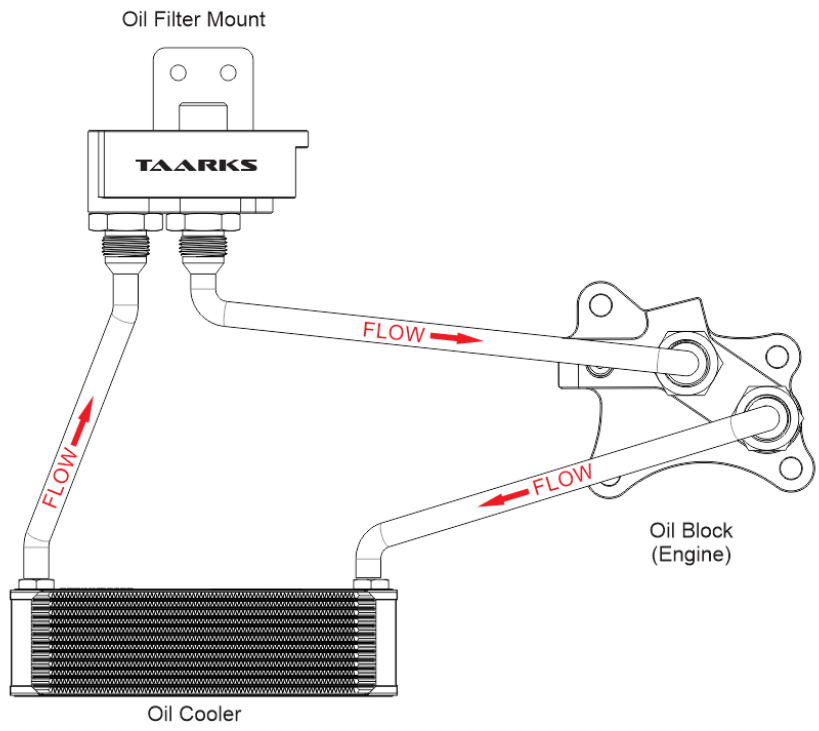

Without oil cooler....

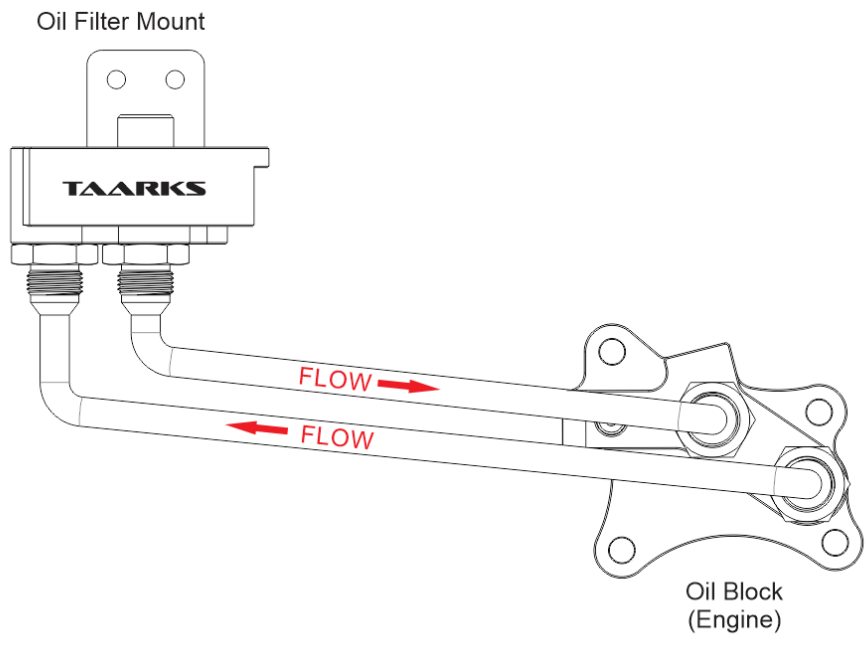

And that's it... You're all done. Enjoy & and thank you for supporting TAARKS.